





5120124/02

INSTALLER GUIDE

LPG (PROPANE) COMBINED CONVERSION KIT 0595251.
CONTAINS KITS 0595231 & 0595221.

This is NOT a DIY kit. Conversion must only be undertaken by a CORGI registered engineer.

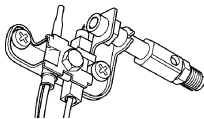
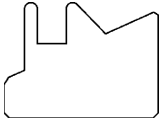
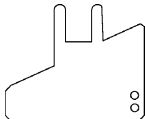
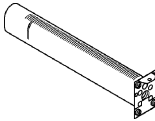
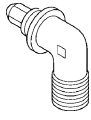
Contents:

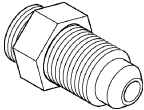
Description	Spares Number	Qty.	Reference	Which model?	Picture (Not to scale)
Pilot burner assembly	5112510	1	SU - 020	946	
Injector alignment gauge	5113310	1		946	
Injector alignment gauge	5108895	1		746 & 956	
Burner assembly	5109353	1		All	
Injector & carrier assembly	5108996	1	(Injector stamped 128)	All	
Data plate label	5108644	1		All	
Pilot injector	5108552	1	Copreci RBM 180-02 (Stamped 225)	746 & 956	

Important: Always turn off the gas supply and allow the appliance to cool completely before commencing any parts replacement or servicing (The inlet ‘T’ connector for this appliance incorporates an isolating valve).

Installation of Conversion Kit 0595231 (Model 946)

Pilot.

1. Replace the natural gas pilot with the LPG pilot. For instructions, please refer to the ‘Servicing and parts replacement’ section of the installer guide supplied with the appliance.

Burner.

1. Screw the LPG injector and carrier assembly into the LPG burner.
2. Replace the natural gas burner with the LPG burner. For instructions, please refer to the ‘Servicing and parts replacement’ section of the installer guide supplied with the appliance.
3. The kit contains an injector alignment gauge. It is important that this gauge is used to ensure that the injector is correctly aligned with the burner. Failure to check may result in poor combustion. After fitting the LPG burner place the gauge into the cut out at the side of the burner tray. The slot in the gauge should surround the injector as in figure 1. If the gauge will not fit, the injector alignment will require correction. To do this, support the top of the injector and gently rotate it. Continue to rotate and check with the gauge until correct.

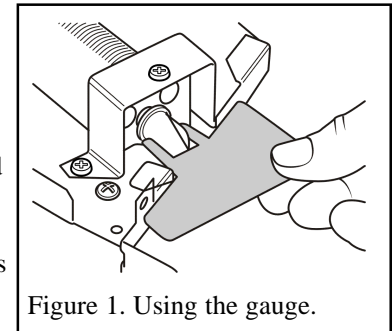

Figure 1. Using the gauge.

Data label

1. The data plate is located below the burner. The data label supplied in the kit must cover the relevant / similar information only. Peel off the backing on the LPG data label and place this on top of the relevant area of the data plate.

Important: Always ensure gas soundness, sealing, spillage test and performance are satisfactory in accordance with installer guide supplied with the appliance and with current regulations.

Installation of Conversion Kit 0595221 (Model 746 & 956)

Pilot injector (See figure 2).

1. You may note that the installer guide supplied with the gas fire states that the pilot must be replaced as a whole assembly and that its individual components are not separately replaceable. When fitting this conversion kit this can be ignored.

1. Support the pilot injector. Unscrew and remove the pilot pipe from the pilot assembly.
2. Support the pilot body. Unscrew and remove the pilot injector.
3. Fit the LPG pilot injector.
4. Re-connect the pilot pipe.

Burner and injector

1. Remove the LPG injector and burner from the pack. Screw the LPG injector into the LPG burner.
2. Replace the natural gas burner with the LPG burner. For instructions, please refer to the ‘Servicing and parts replacement’ section of the installer guide supplied with the appliance.
3. The kit contains an injector alignment gauge. It is important that this gauge is used to ensure that the injector is correctly aligned with the burner. Failure to check may result in poor combustion. After fitting the LPG burner place the gauge into the cut out at the side of the burner tray. The slot in the gauge should surround the injector as in figure 1. If the gauge will not fit, the injector alignment will require correction. To do this, support the top of the injector and gently rotate it. Continue to rotate and check with the gauge until correct.

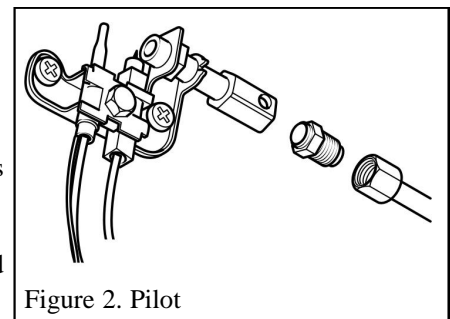

Figure 2. Pilot

Data label

1. The data plate is located below the burner. The data label supplied in the kit must cover the relevant / similar information only. Peel off the backing on the LPG data label and place this on top of the relevant area of the data plate.

Important: Always ensure gas soundness, sealing, spillage test and performance are satisfactory in accordance with installer guide supplied with the appliance and with current regulations.